

PLAN VIEW

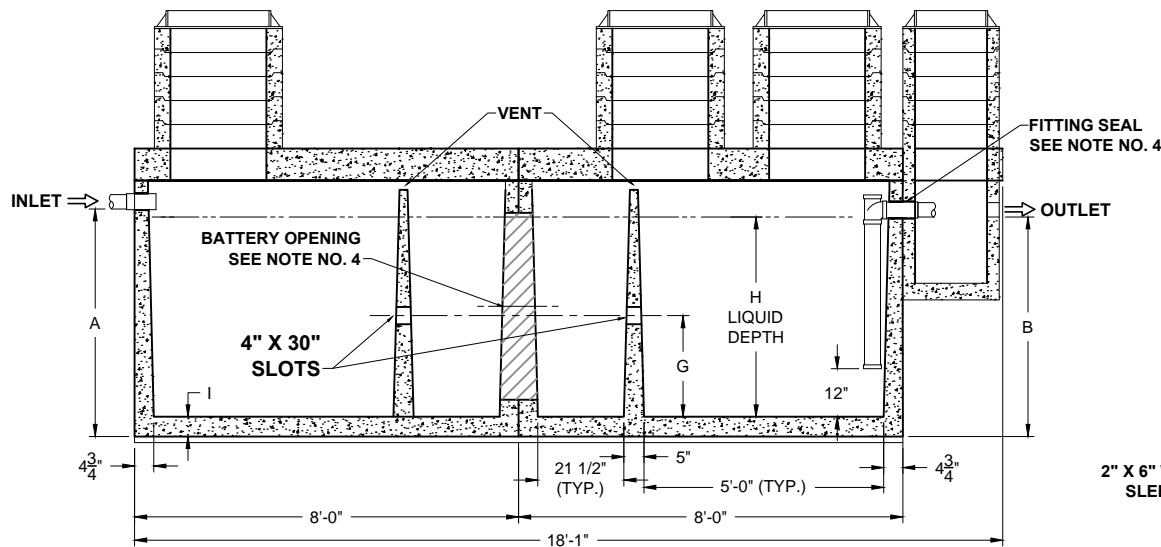

SECTION THRU "A-A"

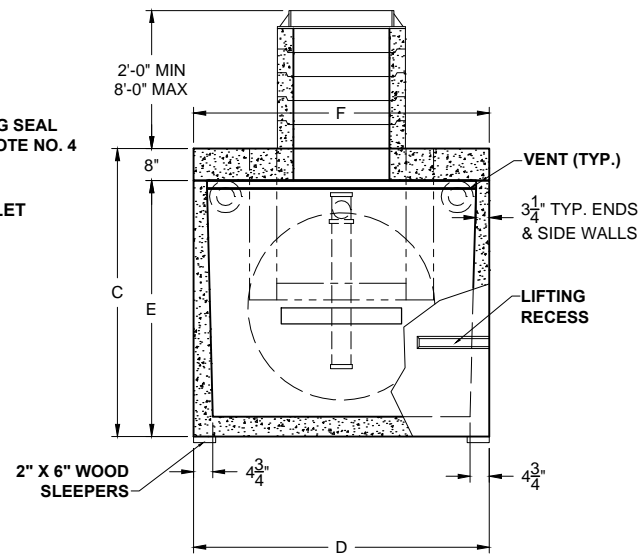

SECTION THRU "B-B"

ALL DIMENSIONS ARE IN INCHES & WEIGHTS IN LBS - (RISER WT. NOT INCLUDED)										
MODEL	A	B	C	D	E	F	G	H	I	WEIGHT
SG3-HD-2-2000	48	46	63	74	55	74	24 3/4	41 1/2	4 1/2	29,020
SG3-HD-2-2500	57	55	72	74	64	74	29 3/4	50 1/2	4 1/2	31,450
SG3-HD-2-3000	60 1/2	58 1/2	75 1/2	85	67 1/2	85	30 3/4	53 1/2	5	36,690

EXCAVATION SPECIFICATIONS			
MODEL	SG-2000	SG-2500	SG-3000
LENGTH	21'-0"	21'-0"	21'-0"
WIDTH	9'-2"	9'-2"	10'-1"
BELOW INLET	4'-0"	4'-9"	5'-0 1/2"
TANK HEIGHT	5'-3"	6'-0"	6'-3 1/2"

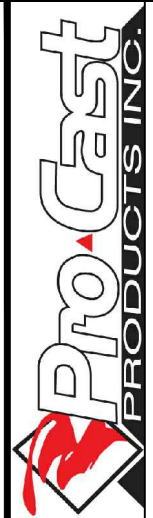

PO Box 602, Highland, CA 92346
 909-793-7602 phone 909-793-1283 fax
 www.procastproducts.com

PRODUCT NAME:
SAND & GREASE INTERCEPTOR

DESCRIPTION:
WITH THREE COMPARTMENTS
2000 THRU 3000 GALLONS

DESIGN SPECIFICATIONS

DESIGN LOAD: H-20 LOADING

WITH DRY SOIL CONDITIONS (WATER LEVEL BELOW TANK). SUITABLE SUB-BASE BEDDED WITH GRANULAR MATERIAL SHALL BE PREPARED TO HANDLE ANTICIPATED LOADS. FOR COMPLETE DESIGN AND PRODUCT INFORMATION, PLEASE CONTACT PRO-CAST PRODUCTS.

PRO-CAST PRODUCTS RESERVES THE RIGHT TO MAKE CHANGES TO PRODUCT DESIGN AND/OR DIMENSIONS WITHOUT NOTICE. PLEASE CONTACT PRO-CAST PRODUCTS WHENEVER NECESSARY FOR CONFIRMATION OR ADVICE ON PRODUCT DESIGN.

- NOTES:**
1. REFER TO SPECIFICATION SHEET NO. S-101
 2. REFER TO SPECIFICATION SHEET NOS. S-251 & S-252
 3. REFER TO SPECIFICATION SHEET NO. S-201
 4. REFER TO SPECIFICATION SHEET NO. S-250

SCALE: 1/4" = 1'-0"
DRAWN BY: TPC 9/14/2017
REVISED BY:
CHECKED BY:

DRAWING NO.
SG-007