

PO Box 602, Highland, CA 92346
 909-793-7602 phone 909-793-1283 fax
 www.procastproducts.com

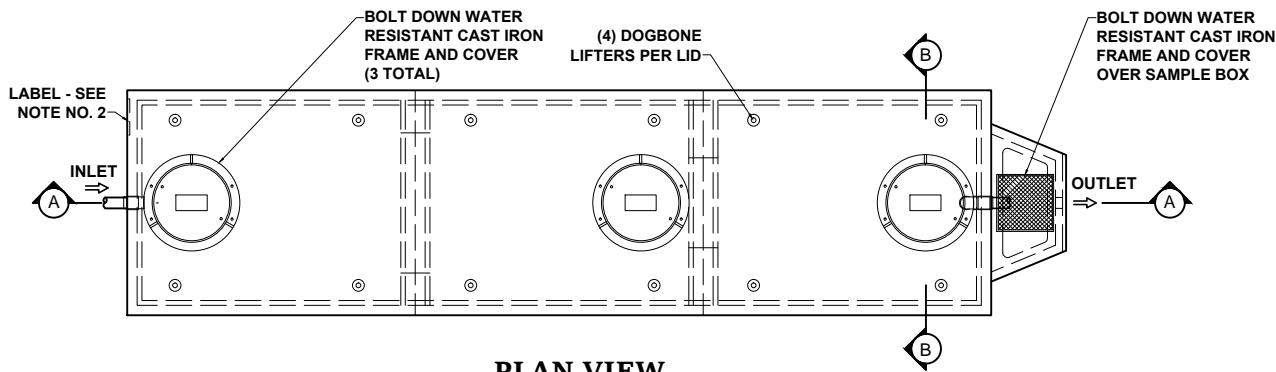

PLAN VIEW

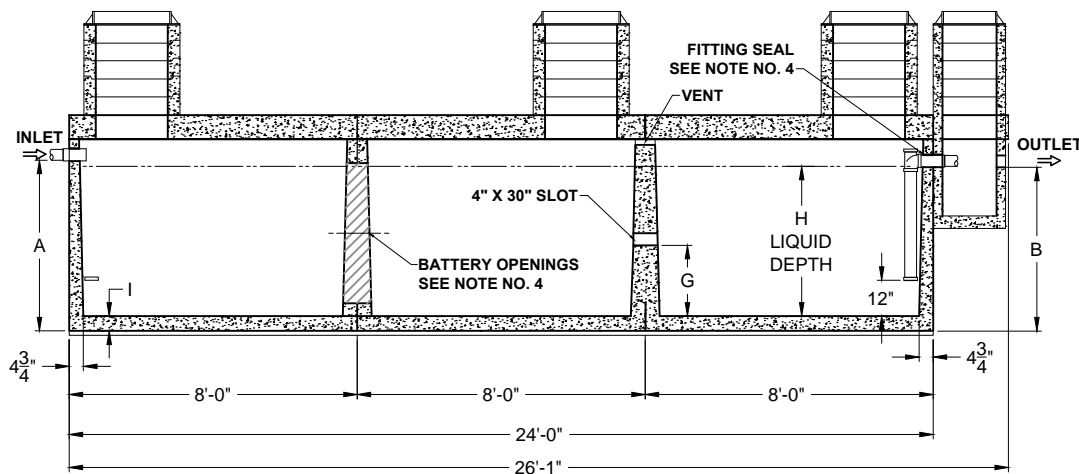

SECTION THRU "A-A"

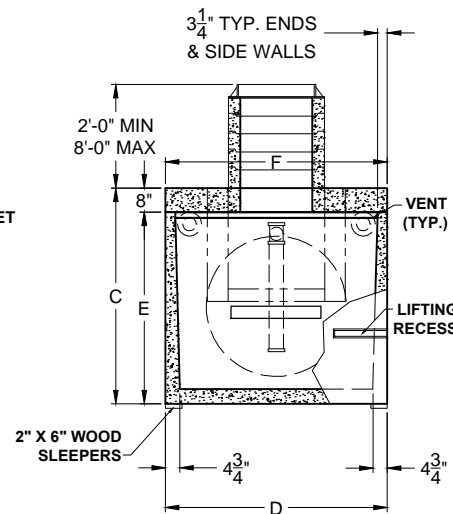

SECTION THRU "B-B"

ALL DIMENSIONS ARE IN INCHES & WEIGHTS IN LBS - (RISER WT. NOT INCLUDED)

MODEL	A	B	C	D	E	F	G	H	I	WEIGHT
SG2-HD-3-3750	57	55	72	74	64	74	25 3/4	50 1/2	4 1/2	47,175
SG2-HD-3-4500	60 1/2	58 1/2	75 1/2	85	67 1/2	85	26 3/4	53 1/2	5	55,035

EXCAVATION SPECIFICATIONS

MODEL	SG-3750	SG-4500
LENGTH	29'-0"	29'-0"
WIDTH	9'-2"	10'-1"
BELOW INLET	4'-9"	5'-0 1/2"
TANK HEIGHT	6'-0"	6'-3 1/2"

PRODUCT NAME:
SAND & GREASE INTERCEPTOR

DESCRIPTION:
 WITH TWO COMPARTMENTS
 3750 THRU 4500 GALLONS

DESIGN SPECIFICATIONS

DESIGN LOAD: H-20 LOADING

WITH DRY SOIL CONDITIONS (WATER LEVEL BELOW TANK). SUITABLE SUB-BASE BEDDED WITH GRANULAR MATERIAL SHALL BE PREPARED TO HANDLE ANTICIPATED LOADS. FOR COMPLETE DESIGN AND PRODUCT INFORMATION, PLEASE CONTACT PRO-CAST PRODUCTS.

PRO-CAST PRODUCTS RESERVES THE RIGHT TO MAKE CHANGES TO PRODUCT DESIGN AND/OR DIMENSIONS WITHOUT NOTICE. PLEASE CONTACT PRO-CAST PRODUCTS WHENEVER NECESSARY FOR CONFIRMATION OR ADVICE ON PRODUCT DESIGN.

- NOTES:
1. REFER TO SPECIFICATION SHEET NO. S-101
 2. REFER TO SPECIFICATION SHEET NOS. S-251 & S-252
 3. REFER TO SPECIFICATION SHEET NO. S-201
 4. REFER TO SPECIFICATION SHEET NO. 250

SCALE: 3/16" = 1'-0"

DRAWN BY: TPC 9/14/2017

REVISED BY:

CHECKED BY:

DRAWING NO.
SG-003