

PLAN VIEW

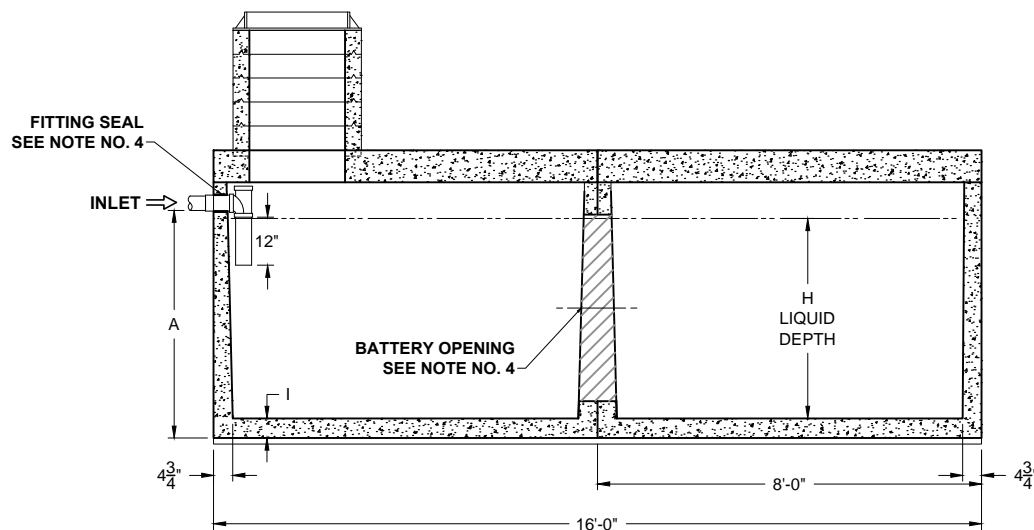

SECTION THRU "A-A"

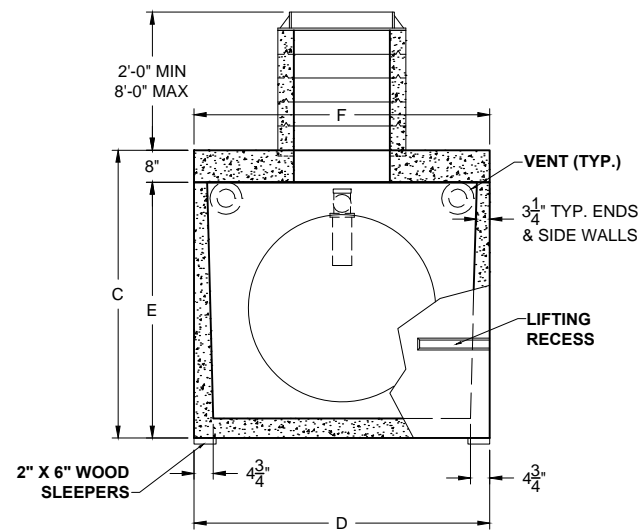

SECTION THRU "B-B"

ALL DIMENSIONS ARE IN INCHES & WEIGHTS IN LBS - (RISER WT. NOT INCLUDED)

MODEL	A	B	C	D	E	F	G	H	I	WEIGHT
H-HD-2-2000	48	N/A	63	74	55	74	N/A	41 1/2	4 1/2	29,020
H-HD-2-2500	57	N/A	72	74	64	74	N/A	50 1/2	4 1/2	31,450
H-HD-2-3000	60 1/2	N/A	75 1/2	85	67 1/2	85	N/A	53 1/2	5	36,690

EXCAVATION SPECIFICATIONS

MODEL	H-2000	H-2500	H-3000
LENGTH	19'-0"	19'-0"	19'-0"
WIDTH	9'-2"	9'-2"	10'-1"
BELOW INLET	4'-0"	4'-9"	5'-0 1/2"
TANK HEIGHT	5'-3"	6'-0"	6'-3 1/2"

PRODUCT NAME:
HOLDING TANK

DESCRIPTION:
WITH ONE MANHOLE & RISERS
2000 THRU 3000 GALLONS

DESIGN SPECIFICATIONS

DESIGN LOAD: H-20 LOADING

WITH DRY SOIL CONDITIONS (WATER LEVEL BELOW TANK). SUITABLE SUB-BASE BEDDED WITH GRANULAR MATERIAL SHALL BE PREPARED TO HANDLE ANTICIPATED LOADS. FOR COMPLETE DESIGN AND PRODUCT INFORMATION, PLEASE CONTACT PRO-CAST PRODUCTS.

PRO-CAST PRODUCTS RESERVES THE RIGHT TO MAKE CHANGES TO PRODUCT DESIGN AND/OR DIMENSIONS WITHOUT NOTICE. PLEASE CONTACT PRO-CAST PRODUCTS WHENEVER NECESSARY FOR CONFIRMATION OR ADVICE ON PRODUCT DESIGN.

NOTES:

1. REFER TO SPECIFICATION SHEET NO. S-101
2. REFER TO SPECIFICATION SHEET NOS. S-251 & S-252
3. REFER TO SPECIFICATION SHEET NO. S-201
4. REFER TO SPECIFICATION SHEET NO. S-250

SCALE: 1/4"=1'-0"

DRAWN BY: TPC 9/14/2017

REVISED BY:

CHECKED BY:

DRAWING NO.

H-007