

PLAN VIEW

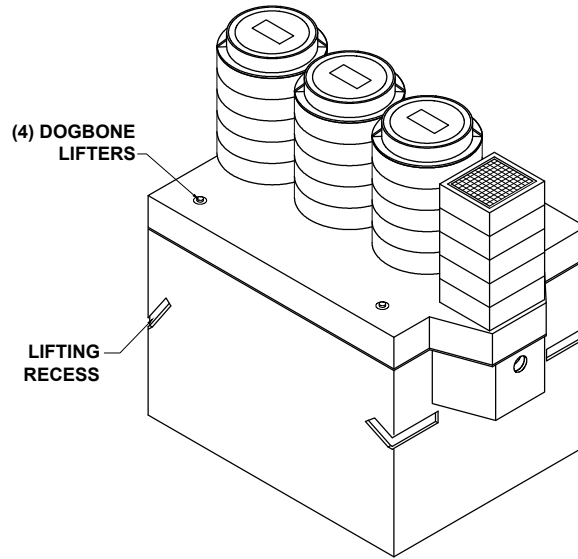

ISOMETRIC VIEW

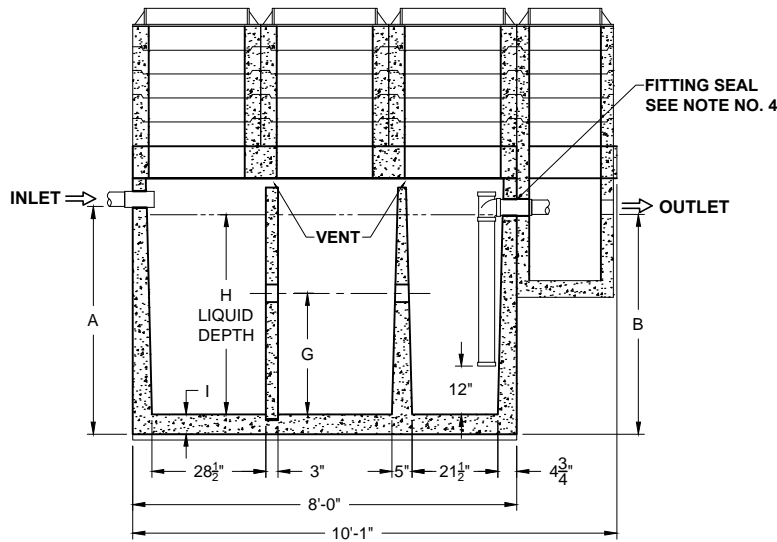

SECTION THRU "A-A"

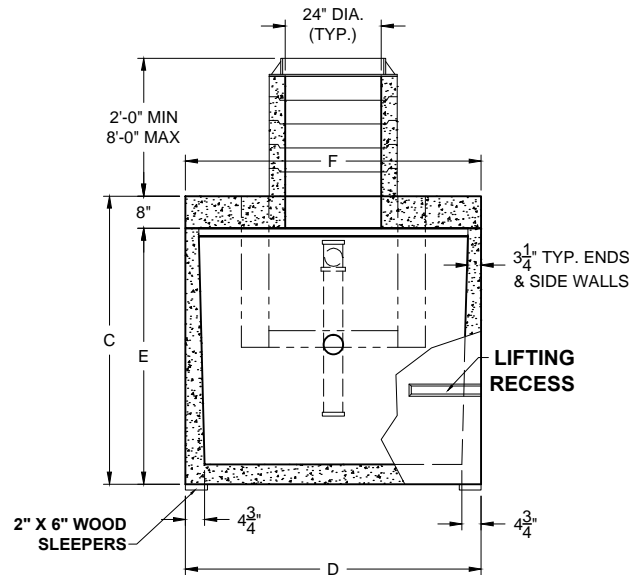

SECTION THRU "B-B"

ALL DIMENSIONS ARE IN INCHES & WEIGHTS IN LBS - (RISER WT. NOT INCLUDED)

MODEL	A	B	C	D	E	F	G	H	I	WEIGHT
C-HD-1-750	38	36	53	74	45	74	19 3/4	31 1/2	4 1/2	13,155
C-HD-1-1000	48	46	63	74	55	74	24 3/4	41 1/2	4 1/2	14,510
C-HD-1-1250	57	55	72	74	64	74	29 3/4	50 1/2	4 1/2	15,725
C-HD-1-1500	60 1/2	58 1/2	75 1/2	85	67 1/2	85	30 3/4	53 1/2	5	18,345

EXCAVATION SPECIFICATIONS

MODEL	C-750	C-1000	C-1250	C-1500
LENGTH	13'-0"	13'-0"	13'-0"	13'-0"
WIDTH	9'-2"	9'-2"	9'-2"	10'-1"
BELOW INLET	3'-2"	4'-0"	4'-9"	5'-0 1/2"
TANK HEIGHT	4'-5"	5'-3"	6'-0"	6'-3 1/2"



PRODUCT NAME:
CLARIFIER

DESCRIPTION:
WITH THREE COMPARTMENTS
750 THRU 1500 GALLONS

DESIGN SPECIFICATIONS

DESIGN LOAD: H-20 LOADING

WITH DRY SOIL CONDITIONS (WATER LEVEL BELOW TANK). SUITABLE SUB-BASE BEDDED WITH GRANULAR MATERIAL SHALL BE PREPARED TO HANDLE ANTICIPATED LOADS. FOR COMPLETE DESIGN AND PRODUCT INFORMATION, PLEASE CONTACT PRO-CAST PRODUCTS.

PRO-CAST PRODUCTS RESERVES THE RIGHT TO MAKE CHANGES TO PRODUCT DESIGN AND/OR DIMENSIONS WITHOUT NOTICE. PLEASE CONTACT PRO-CAST PRODUCTS WHENEVER NECESSARY FOR CONFIRMATION OR ADVICE ON PRODUCT DESIGN.

NOTES:

- (NOT USED)
- REFER TO SPECIFICATION SHEET NOS. S-251 & S-252
- REFER TO SPECIFICATION SHEET NO. S-201
- REFER TO SPECIFICATION SHEET NO. S-250

SCALE: 1/4"=1'-0"

DRAWN BY: TPC 9/14/2017

REVISED BY:

CHECKED BY:

DRAWING NO.

C-001