

1 PANEL ASSEMBLY ELEVATION
N.T.S

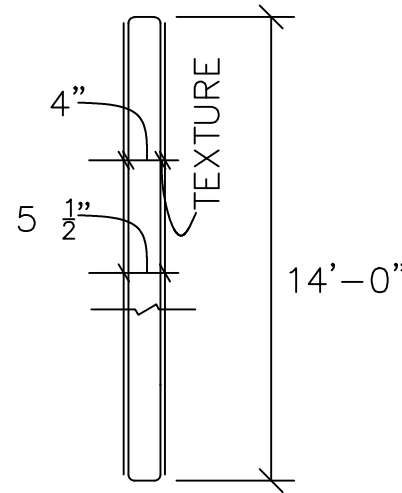

6 PANEL CROSS SECTION
N.T.S

ARCHITECTURAL TEXTURE
TO MATCH EXISTING WALL

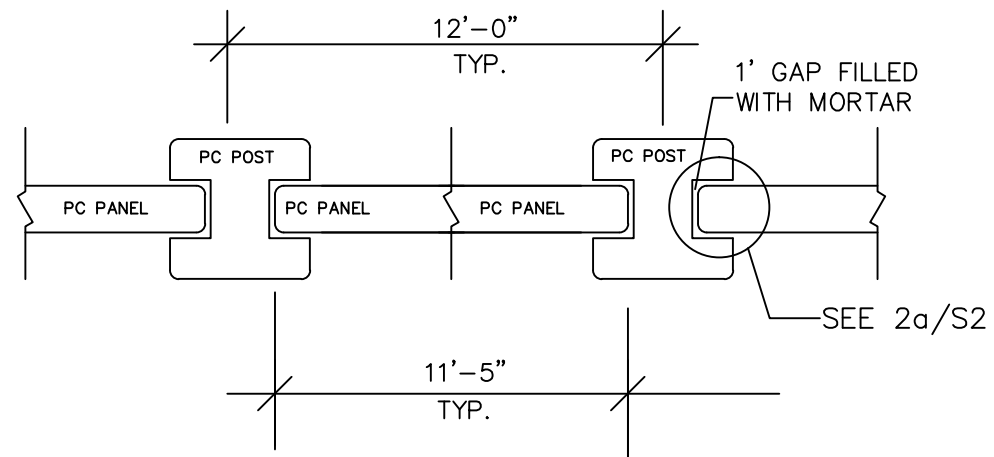

2 PANEL ASSEMBLY PLAN
N.T.S

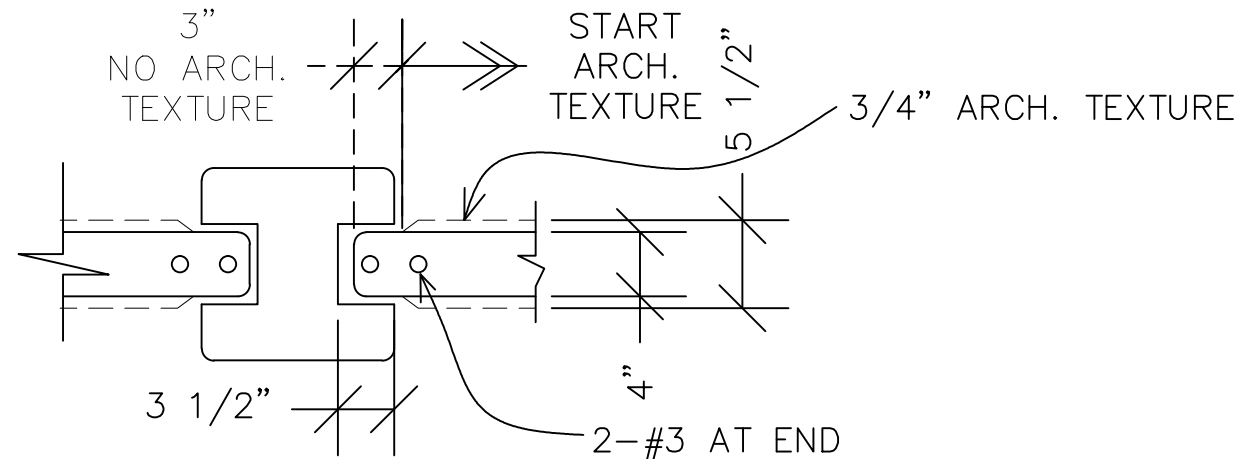

2a PANEL END DETAIL
N.T.S

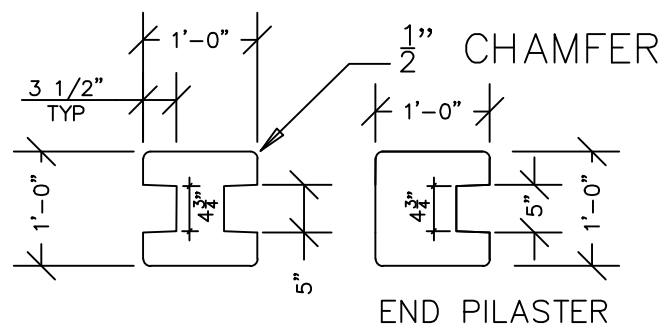

3 PC POST DETAIL
(ABOVE SUB-GRADE)
N.T.S

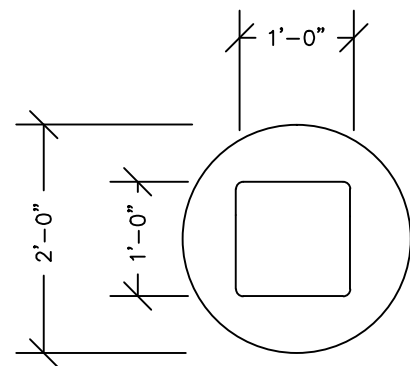

4 PC POST DETAIL
(BELOW SUB-GRADE)
N.T.S

PRO-CAST
PRODUCTS
INC

PO BOX 602
HIGHLAND, CA 92346
Tel. 909-793-7602
Fax. 909-793-1283
www.procastproducts.com

Project:

SW-1
04-Ala-580-R8.4-R14.6
Contract 04-2908C4
PRECAST SOUND WALL

PRECASTER:

PRO-CAST PRODUCTS INC
PO BOX 602
HIGHLAND, CA 92346
Tel. 909-793-7602
Fax. 909-793-1283

Owner/Client:

GHILOTTI CONSTRUCTION
246 GHILOTTI AVE
SANTA ROSA, CA

Stamp:

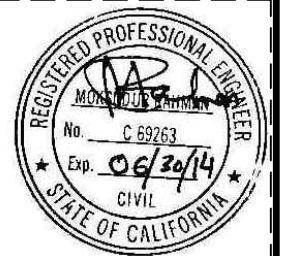

REVISIONS:

MARK:	DATE:	DESCRIPTION/BY:

DRAWN BY: MR.

LAST UPDATED BY:

DRAFTER NAME:	DATE:
XX	XX
XX	XX
XX	XX
XX	XX

DESIGNED BY: MR

CHECKED BY: MR

ISSUE DATE: 04-30-13

PROJECT NUMBER:

SHEET TITLE:
PRECAST PANELS ASSEMBLY
DETAIL

PAGE NO:

S2

SW-1 (STA 79225.04 TO STA 79557.04)
04-Ala-580-R8.4R14.6
CONTRACT 04-2908C4