

PLAN VIEW

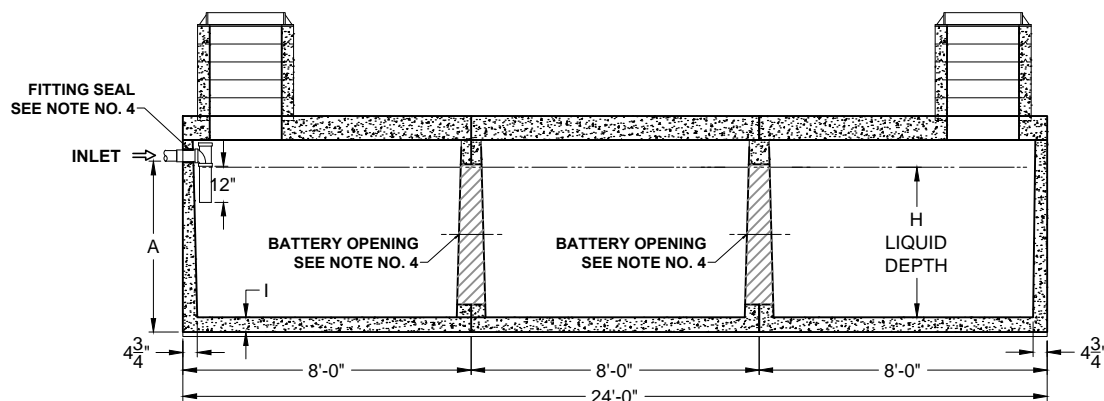

SECTION THRU "A-A"

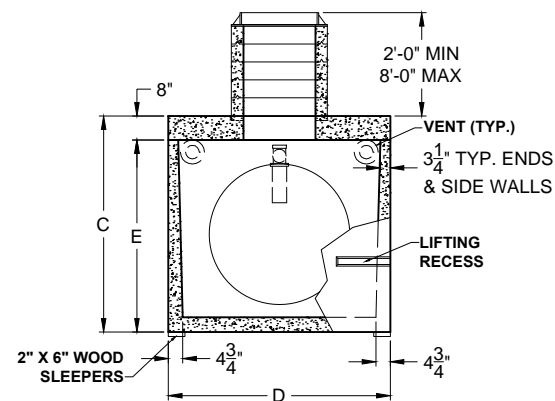

SECTION THRU "B-B"

PRODUCT NAME:
HOLDING TANK

DESCRIPTION:
WITH TWO MANHOLES & RISERS
3750 TO 4500 GALLONS

DESIGN SPECIFICATIONS

DESIGN LOAD: H-20 LOADING

WITH DRY SOIL CONDITIONS (WATER LEVEL BELOW TANK). SUITABLE SUB-BASE BEDDED WITH GRANULAR MATERIAL SHALL BE PREPARED TO HANDLE ANTICIPATED LOADS. FOR COMPLETE DESIGN AND PRODUCT INFORMATION, PLEASE CONTACT PRO-CAST PRODUCTS.

PRO-CAST PRODUCTS RESERVES THE RIGHT TO MAKE CHANGES TO PRODUCT DESIGN AND/OR DIMENSIONS WITHOUT NOTICE. PLEASE CONTACT PRO-CAST PRODUCTS WHENEVER NECESSARY FOR CONFIRMATION OR ADVICE ON PRODUCT DESIGN.

- NOTES:**
1. REFER TO SPECIFICATION SHEET NO. S-101
 2. REFER TO SPECIFICATION SHEET NOS. S-251 & S-252
 3. REFER TO SPECIFICATION SHEET NO. S-201
 4. REFER TO SPECIFICATION SHEET NO. S-250

SCALE: 3/16" = 1'-0"

DRAWN BY: TPC 9/14/2017

REVISED BY:

CHECKED BY:

DRAWING NO.

H-008

ALL DIMENSIONS ARE IN INCHES & WEIGHTS IN LBS - (RISER WT. NOT INCLUDED)

MODEL	A	B	C	D	E	F	G	H	I	WEIGHT
H-HD-3-3750	57	N/A	72	74	64	74	N/A	50 1/2	4 1/2	47,175
H-HD-3-4500	60 1/2	N/A	75 1/2	85	67 1/2	85	N/A	53 1/2	5	55,035

EXCAVATION SPECIFICATIONS

MODEL	H-3750	H-4500
LENGTH	27'-0"	27'-0"
WIDTH	9'-2"	10'-1"
BELOW INLET	4'-9"	5'-0 1/2"
TANK HEIGHT	6'-0"	6'-3 1/2"