

PLAN VIEW

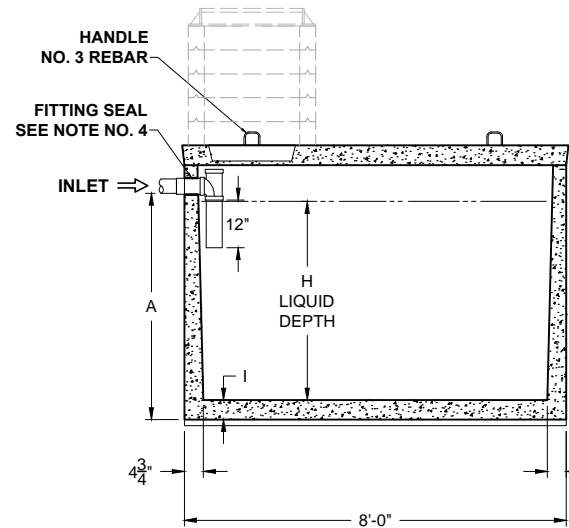

SECTION THRU "A-A"

OPTIONAL GRADE RINGS WITH CAST IRON LID (BACKFILL CONDITION)

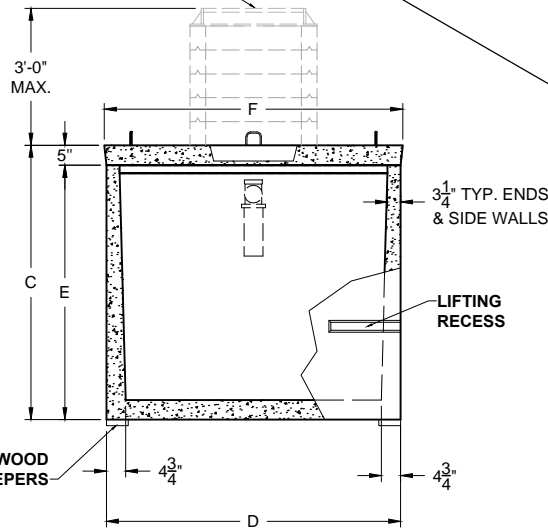

SECTION THRU "B-B"

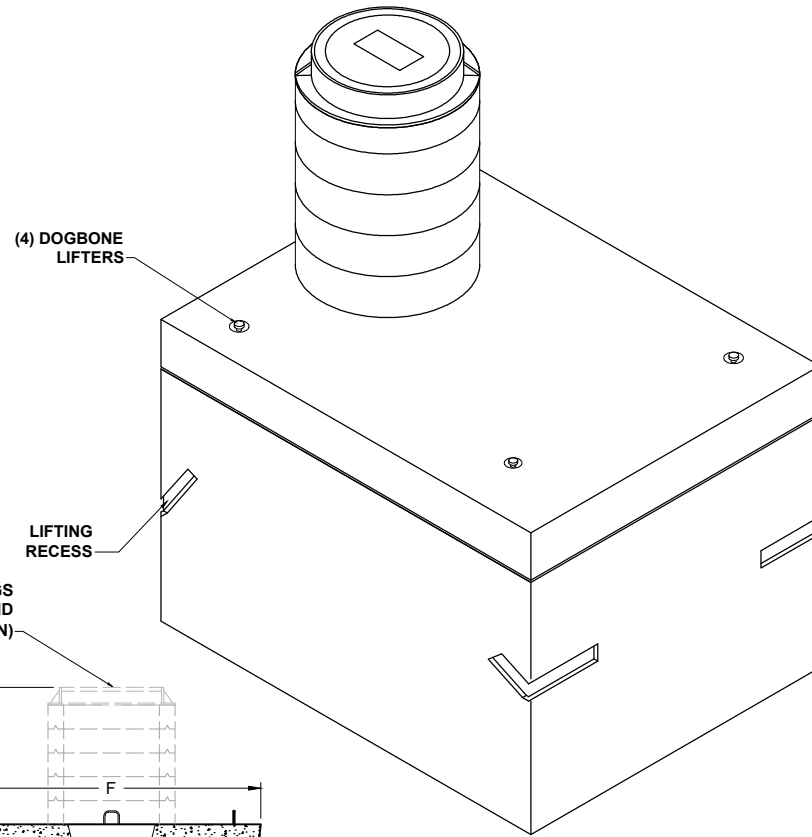

ISOMETRIC VIEW



PRODUCT NAME:
HOLDING TANK

DESCRIPTION:
WITH ONE MANHOLE
500 THRU 1500 GALLONS

DESIGN SPECIFICATIONS

DESIGN LOAD: PEDESTRIAN
(300 PSF)

WITH DRY SOIL CONDITIONS (WATER LEVEL BELOW TANK). SUITABLE SUB-BASE BEDDED WITH GRANULAR MATERIAL SHALL BE PREPARED TO HANDLE ANTICIPATED LOADS. FOR COMPLETE DESIGN AND PRODUCT INFORMATION, PLEASE CONTACT PRO-CAST PRODUCTS.

PRO-CAST PRODUCTS RESERVES THE RIGHT TO MAKE CHANGES TO PRODUCT DESIGN AND/OR DIMENSIONS WITHOUT NOTICE. PLEASE CONTACT PRO-CAST PRODUCTS WHENEVER NECESSARY FOR CONFIRMATION OR ADVICE ON PRODUCT DESIGN.

NOTES:

1. (NOT USED)
2. REFER TO SPECIFICATION SHEET NOS. S-251 & S-252
3. REFER TO SPECIFICATION SHEET NO. S-201
4. REFER TO SPECIFICATION SHEET NO. S-250

SCALE: 1/4"=1'-0"

DRAWN BY: TPC 9/14/2017

REVISED BY:

CHECKED BY: -- --

DRAWING NO.

H-001

ALL DIMENSIONS ARE IN INCHES & WEIGHTS IN LBS - (RISER WT. NOT INCLUDED)

MODEL	A	B	C	D	E	F	G	H	I	WEIGHT
H-LD-1-500	46	N/A	58	74	51	75	N/A	39	4 1/2	10,065
H-LD-1-750	38	N/A	50	74	45	75	N/A	31 1/2	4 1/2	11,305
H-LD-1-1000	48	N/A	60	74	55	75	N/A	41 1/2	4 1/2	12,660
H-LD-1-1250	57	N/A	69	74	64	75	N/A	50 1/2	4 1/2	13,875
H-LD-1-1500	60 1/2	N/A	72 1/2	85	67 1/2	86	N/A	53 1/2	5	16,220

EXCAVATION SPECIFICATIONS

MODEL	H-500	H-750	H-1000	H-1250	H-1500
LENGTH	9'-6"	11'-0"	11'-0"	11'-0"	11'-0"
WIDTH	7'-6"	9'-2"	9'-2"	9'-2"	10'-1"
BELOW INLET	3'-10"	3'-2"	4'-0"	4'-9"	5'-0 1/2"
TANK HEIGHT	4'-11"	4'-2"	5'-0"	5'-9"	6'-0 1/2"